

Installation Instructions - SMR-1-500 - 3" Deflection spring mount

SMRF-1-500 (Flat Top), Figure 2

1a) Check each spring mount's model number before installation. Locate each spring mount into position based on submittal drawings or the equipment's load distribution chart.

2a) Secure the spring mount's bottom frame (BF) to the equipment support structure or concrete foundation, according to the equipment base's drawings for the locations of the mounting holes. All bolts and anchor hardware must be a minimum of grade 5. If recommended by the engineering consulting agency or installation engineer a higher grade hardware, then follow their recommendation. If spring mounts are welded in position, remove the rubber pad (RP) before welding.

3a) Use a forklift, crane, or any other certified lifting machine to raise the equipment to be installed. Slowly lower the equipment on top of the spring mounts' top plates (TP) and make sure that the equipment's base is perfectly aligned with the spring mounts' top plates (TP).

4a) When equipment is resting on top of all the spring mounts, the top plate nuts (TN) will rest on top of the bottom frame (BF), and the gap #1 will disappear. Loosen all restraining nuts (RN) to the end of the threaded rods (TR) to allow leveling of the top plate (TP).

5a) Make sure that the top plates (TP) are properly attached or welded to the equipment's base. Welding must achieve the required strength.

6a) Start leveling by turning all leveling bolts (LB) until gap #1 appears (approximately 3/16" to 1/4").

7a) Double-check that each spring mount's dimension "C" (Figure 1) must be bigger than 6 inches. If the dimension "C" is smaller than 6", then the spring mount is overloaded.

8a) Proceed to fine leveling each spring mount by turning the leveling bolt (LB) no more than one turn at a time per each spring mount.

9a) After the equipment's leveling is done, run down the lock nut (LN) and tighten it onto the spring cup (SC).

10a) Adjust and lock the restraining nuts (RN) together, leaving a gap #2 of 3/16 to 1/4" clearance.

11a) Every spring mount **must** have clearances at both gap #1 & gap #2 after the installation is complete.

SMRT-1-500 (Top Bolt), Figure 3

1b) Same than step 1a.

2b) Same than step 2a.

3b) Use a forklift, crane, or any other certified lifting machine to raise the equipment to be installed. Slowly lower the equipment on top of the spring mounts' top plates (TP) and make sure that the equipment's mounting holes are perfectly aligned with the spring mount's top plate's (TP) center threaded hole.

4b) Same than step 4a.

5b) Screw the leveling bolts (LB) on the top plate's (TP) center threaded hole of every spring mount. Turn the leveling bolts clockwise until they sit inside the thrust bolts' (TB) pockets.

6b) Same than step 6a.

7b) Same than step 7a.

8b) Same than step 8a.

9b) After the equipment's leveling is done, run down the lock nut (LN) with washers (W) and tighten them onto the equipment's base.

10b) Same than step 10a.

11b) Same than step 11a.

Note: We recommend that professional millwrights are used to perform the installation.

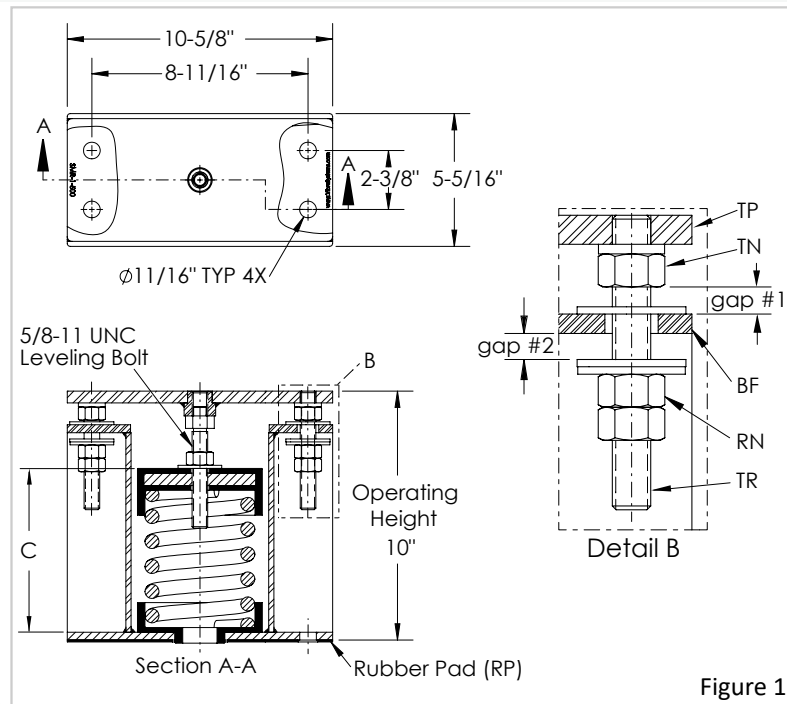
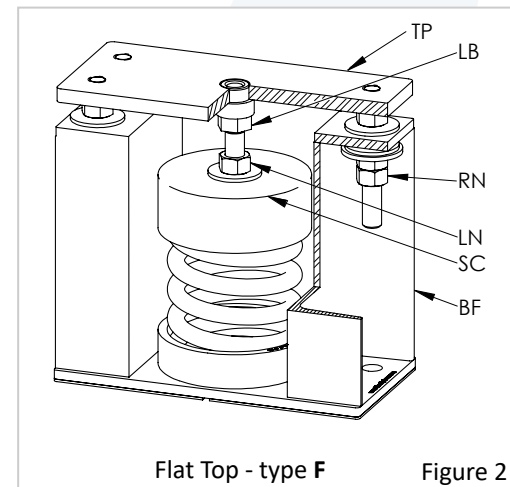
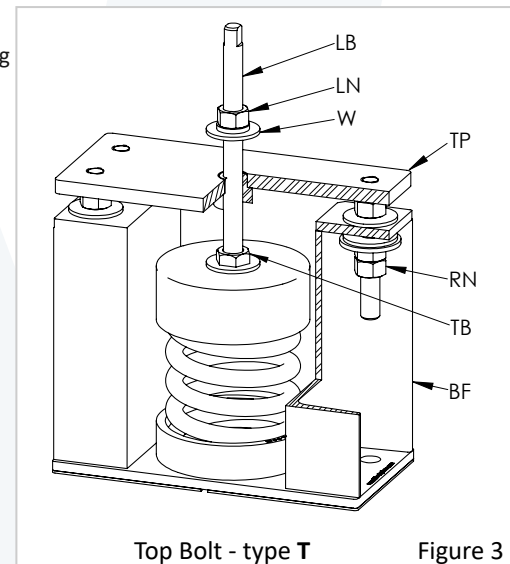

Figure 1



Flat Top - type F Figure 2



Top Bolt - type T Figure 3