

Model	Type "F" or "T"	Rated Load (lbs)	Deflec. @ Rated Load (in)	Spring Rate (lbs/in)	Max. G Rating	Spring Color	QTY
SMR-1-500		200	3	66.7		Black	
SMR-1-501		400	3	133.3		Blue	
SMR-1-502		600	3	200.0		Yellow	
SMR-1-503		800	3	266.7		Orange	
SMR-1-504		1,000	3	333.3		Red	
SMR-1-505		1,200	3	400.0		White	
SMR-1-506		1,500	3	500.0		Brown	
SMR-1-507		2,000	3	666.7		Green	
SMR-1-506-853		2,500	3	833.3		Brown/Grey	
SMR-1-509		3,000	3	1,000.0		Grey	
SMR-1-509-853		4,000	3	1,333.3		Grey/Grey	

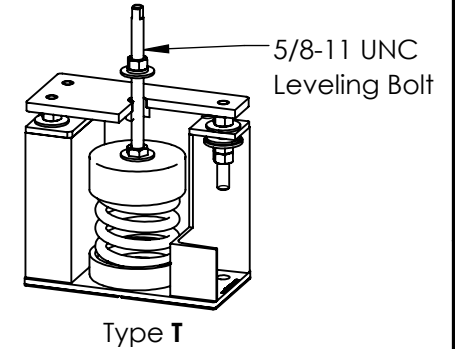
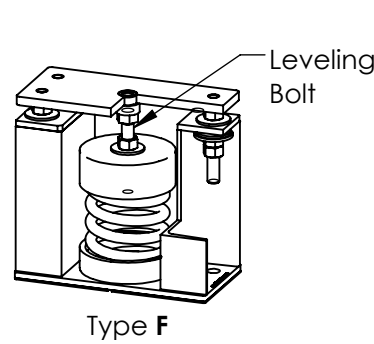
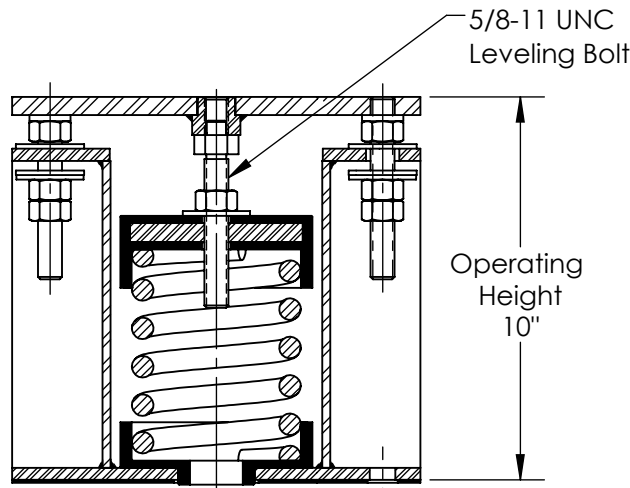

Notes:

- Standard finishing:
 - Housing: Hot-dip Galvanizing;
 - Springs: Powder Coating;
 - Hardware: Zinc-electroplating.
- All springs will accommodate 50% extra load from rated load to solid load.

Isolator Selections	
Pos 1	Pos 2
Pos 3	Pos 4
Pos 5	Pos 6
Pos 7	Pos 8
Pos 9	Pos 10

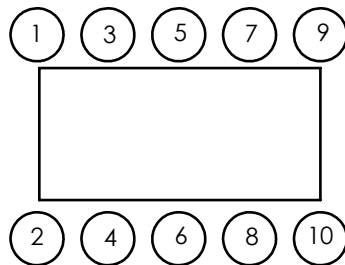

NAME	DATE
DRAWN R.D.	2023-05-19
APPR. --	--
QUANTITY	01
UNLESS OTHERWISE SPECIFIED: 3RD ANGLE PROJECTION DIMENSIONS ARE IN INCHES TOLERANCES: ANGULAR ± 1° FRACTIONAL ± .025 TWO PLACE DECIMAL ± .010 THREE PLACE DECIMAL ± .006	
MODEL: SMR-1-500 series	

VibraSystems Inc

www.vibrasystems.com

PART: Spring Mount Restraint
3" Deflection
SMR-1-500

SIZE DWG. NO. REV
A 117-30-00-C **C**

SCALE: 1:5 DO NOT SCALE DRAWING SHEET 1 OF 1