

Installation Instructions

1) Check each isolator's model number against the information on the packing slip, before beginning installation.

2) Secure the isolator's base plate (BP) to the equipment support structure - concrete foundation or metal frame, according to the equipment base's drawings for the locations of the mounting holes. All bolts and anchor hardware must be a minimum of grade 2. If recommended by the manufacturer or installation engineer a higher grade, then follow their recommendation. All anchors must be installed according to the installation drawings and instructions.

3) Use a forklift, crane, or any other certified lifting machine to raise the equipment to be installed. Slowly lower the equipment on top of the isolators and make sure that the equipment's base is perfectly aligned with the isolator's top plate (BTP or WTP).

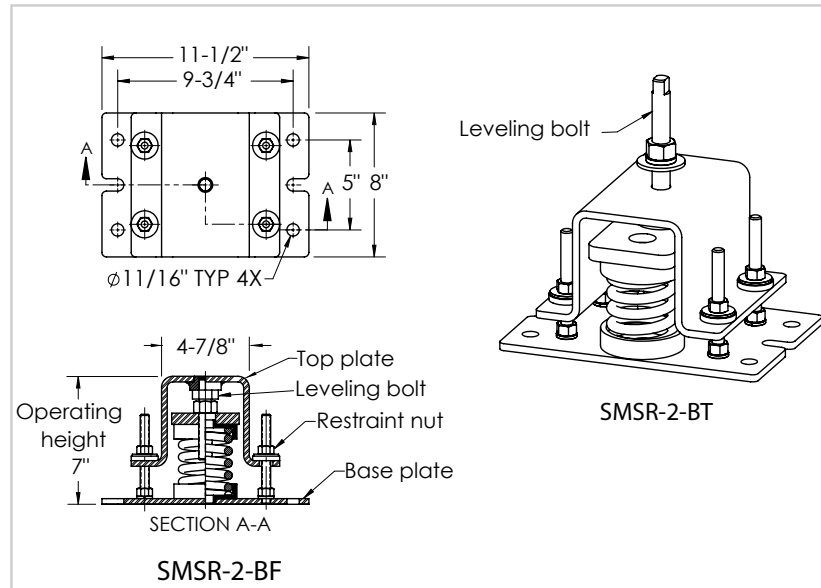

SMSR-2-BT

4a) When the equipment, which must be at the full operating weight, is placed onto the isolator, the isolator's spring will be compressed according to the load vs. deflection chart for this model.

5a) Loosen the restraint nuts (RN) to allow leveling of the top plate (BTP).

6a) Level each isolator in sequence by turning the leveling bolt (LB) a full clockwise turn at a time.

7a) After the leveling is done, run down the lock nut (N) to the equipment's base.

8a) Adjust the vertical restraint nuts (RN) to allow a free movement of the installed equipment with an allowed gap from 1/8" to 3/16".

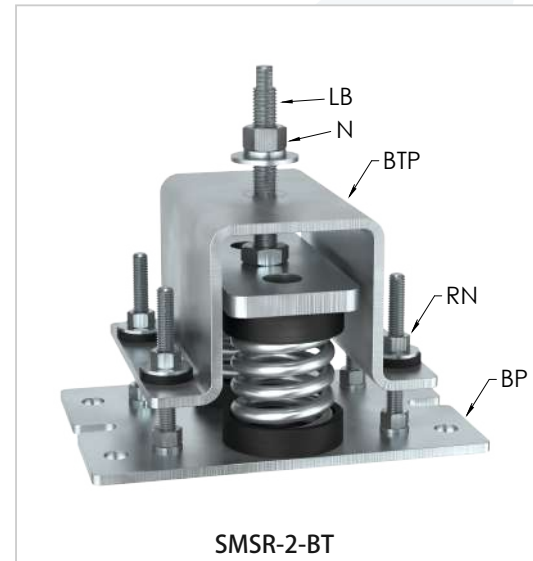

SMSR-2-BT

SMSR-2-BF

4b) Make sure that the top plates (WTP) are properly attached or welded to the equipment's base. Welding to steel base is permitted provided the weld achieves the required strength.

5b) When the equipment, which must be at the full operating weight, is placed onto the isolator, the isolator's spring will be compressed according to the load vs. deflection chart for this model.

6b) Loosen the restraint nuts (RN) to allow leveling of the top plate (WTP).

7b) Level each isolator in sequence by turning the leveling bolt (LB) a full clockwise turn at a time.

8b) After the leveling is done, run down the lock nut (N).

9b) Adjust the vertical restraint nuts (RN) to allow a free movement of the installed equipment with an allowed gap from 1/8" to 3/16".

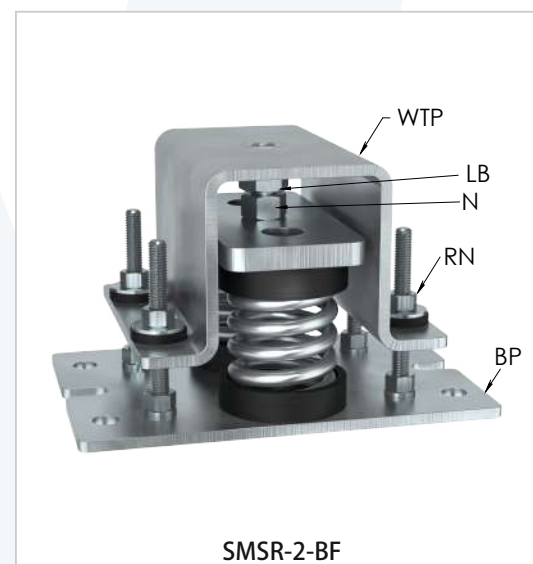

SMSR-2-BF