

1" & 2" DEFLECTION SPRING ELASTOMER HANGERS

HC-S-E models are heavy duty hangers and incorporate a new design of steel housing, with the base's two sides bent down. This considerably increases the rigidity of the steel frame, eliminating the possibility of the bending of the frame's bottom plate under heavy loads. These hangers have three elastomer parts. The top and bottom spring's rubber cups have vulcanized steel washers for even load distribution. The bottom cup has a locator rubber ring to center the cup and spring in the hanger's housing. The third part is an elastomer element with the rubber ring to center the element in the top opening of the housing's frame. Depending on the load, different sizes and hardness of the elements are recommended and available. These elastomer cups reduce the transfer of vibration and noise.



Recommended for:

Spring hangers are used for fan coil units, air circulation units, pipes, ducts, and other suspended structures and building services.

1" Deflection

Model	Rated Load (lbs)	Deflection at Rated Load (in)	Spring Rate (lbs/in)	Spring Color
HC-S-101-E2-40	75	1.50	50	Blue
HC-S-103-E2-60	120	1	120	Brown
HC-S-142-E2-40	135	1.50	90	Blue
HC-S-105-E2-60	270	1	270	Yellow
HC-S-144-E2-60	400	1.50	266	Brown
HC-S-107-E2-60	650	1	650	Green
HC-S-111-E2-80	800	.75	1,066	White
HC-S-146-E2-80	850	1.50	566	Yellow
HC-S-109-E2-80	1,000	.84	1,190	Plated

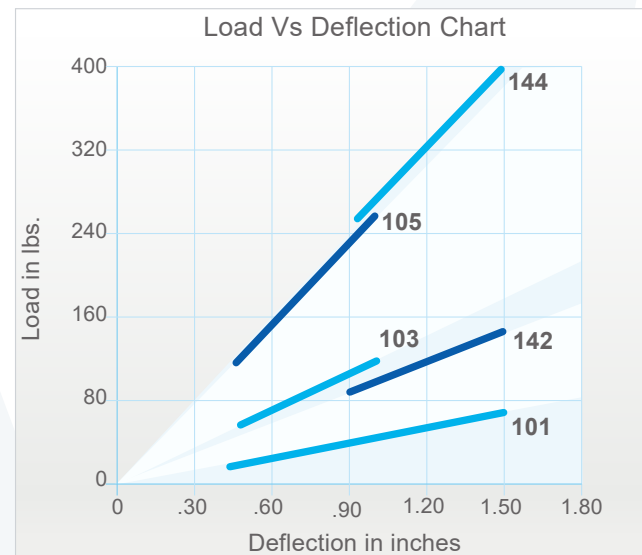

2" Deflection

Model	Rated Load (lbs)	Deflection at Rated Load (in)	Spring Rate (lbs/in)	Spring Color
HC-S-170-E2-40	43	2	21.5	Blue
HC-S-140-E2-40	80	2	40	Black
HC-S-172-E2-40	155	2	77.5	Orange
HC-S-174-E2-60	236	2	118	White
HC-S-175-E2-60	300	2	150	Brown
HC-S-176-E2-60	395	2	197.5	Black
HC-S-178-E2-80	550	2	275	Pink
HC-S-150-E2-80	800	2	400	Grey

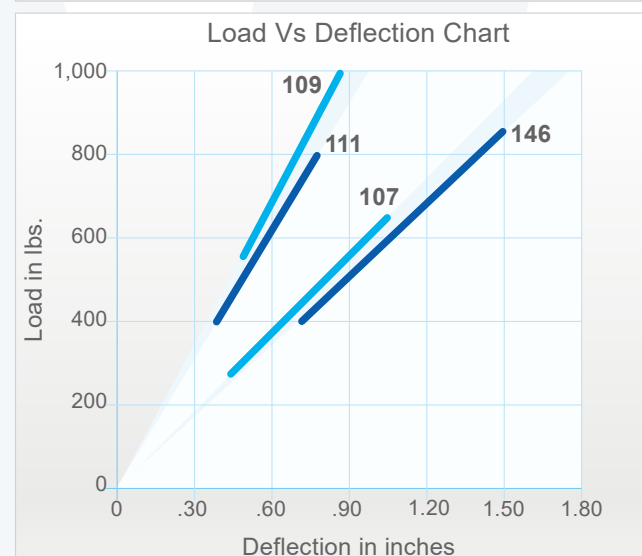

1" & 2" DEFLECTION SPRING ELASTOMER HANGERS

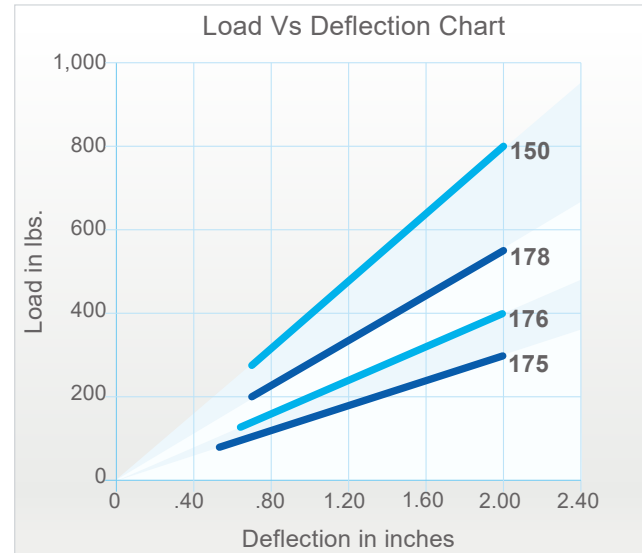
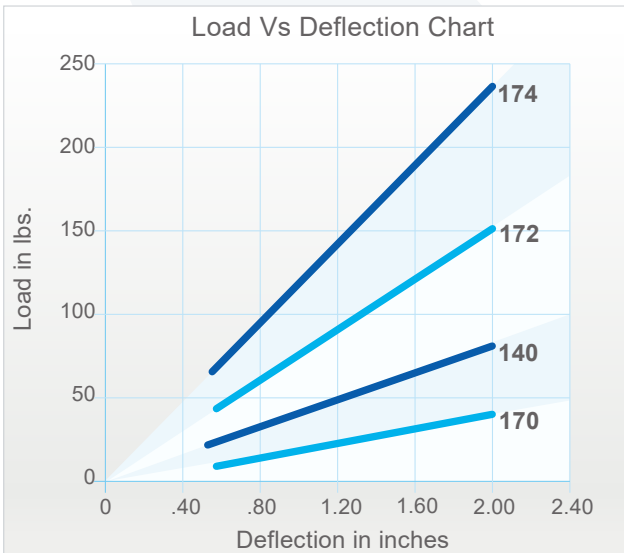

Features:

- ✓ All springs at rated load have 50% additional travel to solid load.
- ✓ Housing is yellow zinc plated for better corrosion resistance.
- ✓ Safety factor - Springs will accommodate 50% extra load from rated to solid load.
- ✓ All hangers' elements are safe at solid load.
- ✓ Springs are color-coded and easily replaceable.

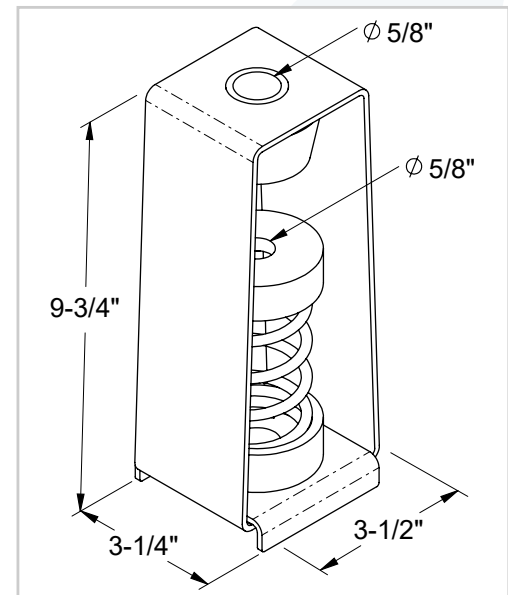

Notes:

- a) 100 Spring: 2" Outside diameter x 4" Free Length.
- b) 140 Spring & 170 Spring: 2" Outside diameter x 5" Free Length.
- c) 150 Spring: 2" Outside diameter x 5-3/4" Free Length.
- d) Rated load is the maximum load recommended.

Installation Instructions:

In order to allow isolators to operate efficiently install hangers with a gap as shown below. Hangers are designed to allow to compensate minor misalignments.

