

2

1

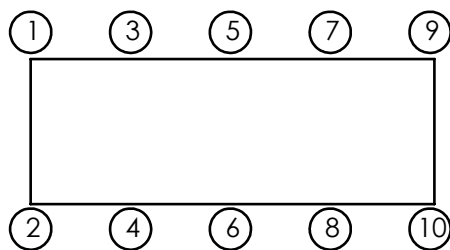
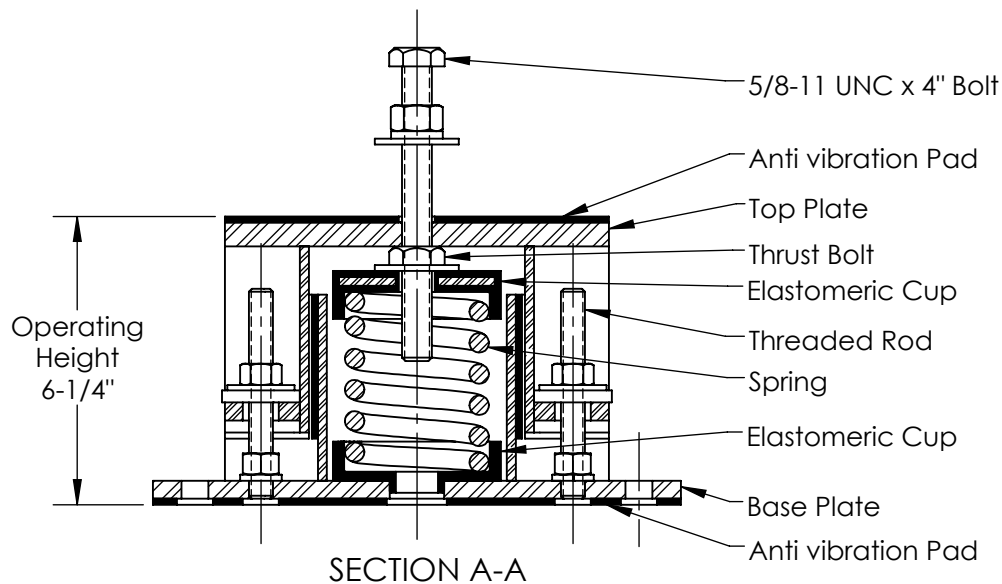
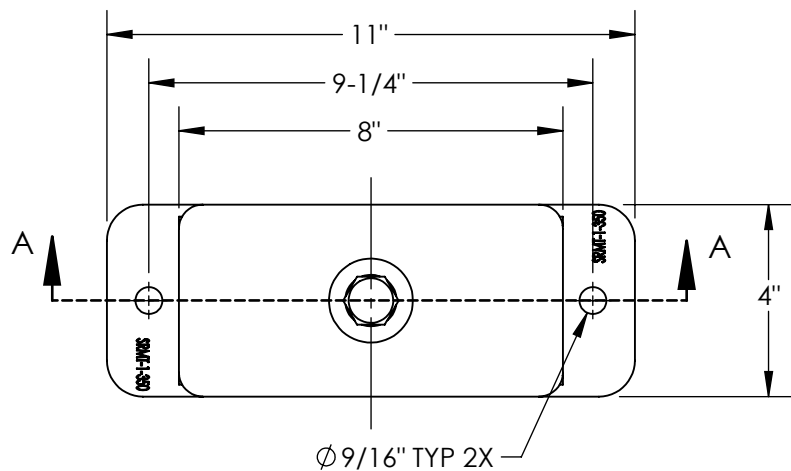

Isolator Selections			
Pos 1		Pos 2	
Pos 3		Pos 4	
Pos 5		Pos 6	
Pos 7		Pos 8	
Pos 9		Pos 10	

Model	Rated Load (lbs)	Deflec. @ Rated Load (in)	Spring Rate (lbs/in)	Max. Combined Vert. / Horiz. G Rating	Spring Color
SRMT-1-352	140	1.5	93	46.3	Yellow
SRMT-1-354	250	1.5	167	25.9	Purple
SRMT-1-354-142	385	1.5	257	16.8	Purple/Blue
SRMT-1-354-144	650	1.5	433	10.0	Purple/Brown
SRMT-1-354-146	1,000	1.5	667	6.5	Purple/Yellow
SRMT-1-354-148	1,300	1.25	1,040	5.0	Purple/Green

Model	Rated Load (lbs)	Deflec. @ Rated Load (in)	Spring Rate (lbs/in)	Max. Combined Vert. / Horiz. G Rating	Spring Color
SRMT-1-350	80	2	40	81.0	Red
SRMT-1-350-140	160	2	80	40.5	Red/Black
SRMT-1-403	348	2	174	18.6	Black
SRMT-1-404	453	2	226.5	14.3	Blue
SRMT-1-405	590	2	295	11.0	Red
SRMT-1-406	676	2	338	9.6	Orange
SRMT-1-407	787	2	393.5	8.2	Green
SRMT-1-408	918	2	459	7.1	White
SRMT-1-409	1,000	2	500	6.5	Brown
SRMT-1-410	1,250	2	625	5.2	White
SRMT-1-407-150	1,437	2	718.5	4.5	Green/Grey
SRMT-1-409-150	1,650	2	825	3.9	Brown/Grey
SRMT-1-410-150	1,900	2	950	3.4	White/Grey

Notes:

- Standard finish: Housing - Zinc Bright Plating; Spring - Zinc Bright Plating (Color: see table); Hardware - Zinc-electroplate.
- Safety factor - Springs will accommodate 50% extra load from rated load to solid load.
- Vibrasystems isolators are tested and certified to ASHRAE 171-2017 for wind and seismic load resistance. Wind and Seismic Certification Compliance Report 1701502-CR-001.

VibraSystems Inc

www.vibrasystems.com
email: info@vibrasystems.com

INSTALLATION INSTRUCTIONS

SCALE: None	MODEL: SRMT-1-350	SHEET 1 OF 2	REV A
-------------	-------------------	--------------	-------

2

1

1. Check each isolator's model number against the information on the packing slip, before beginning installation.
2. Secure the isolator to the equipment support structure - concrete foundation or metal frame, according to the equipment base's drawings for the locations of the mounting holes ("B").
 - 2.1. If the isolator is installed on a concrete foundation, use sets of seismically rated concrete anchors and follow the general anchor installation instructions with the required torque value on the anchor's nut.
 - 2.2. If the isolator is installed on a metal base, use grade 5 or better hardware to secure the isolator to the support base. Welding to steel base is permitted provided the weld achieves the required strength. Remove the rubber pad ("P") before welding.
 - 2.3. Vibrasystems Inc. recommends that all the isolators are installed on a level surface.

3. Use a forklift, crane or any other certified lifting machine to raise the equipment to be installed. Slowly lower the equipment on top of the isolators and make sure that equipment base's holes perfectly aligned with the threaded hole on the isolator's top plate ("D").
4. Make sure that the isolator's Hex Bolt ("L") properly fit through the holes in the base of the equipment and into the threaded hole on the isolator's top plates ("D"). Central bolt must have a flat washer ("N"), a spring washer ("M"), and a hexagon nut ("K") underneath the head of the Hex Bolt ("L"). Welding to steel base is permitted provided the weld achieves the required strength. Remove the rubber pad ("S") before welding.
5. When the equipment, which must be at the full operating weight, is placed onto the isolators, the isolator's spring will be compressed under the load according to the Load VS. Deflection chart for this isolator model. The inside channels ("E") will slide down along the outside channels ("I") of the isolator's base ("C") under the weight of the equipment.
6. Turn the Hex Bolt ("L") clockwise until it touches the bottom of thrust bolt ("J").
7. Level each isolator in sequence by turning Hex Bolt ("L") a full clockwise turn at a time. Repeat this procedure on all isolators, one at a time. After the leveling is done, run down the lock nut ("K"), the spring washer ("M") and the flat washer ("N") to secure the equipment to the isolator's top plate ("D").
8. Adjust the lock nuts ("F") to allow a free movement of the installed equipment at all mounting points, with an allowed gap of 1/4".
9. Installation is complete.

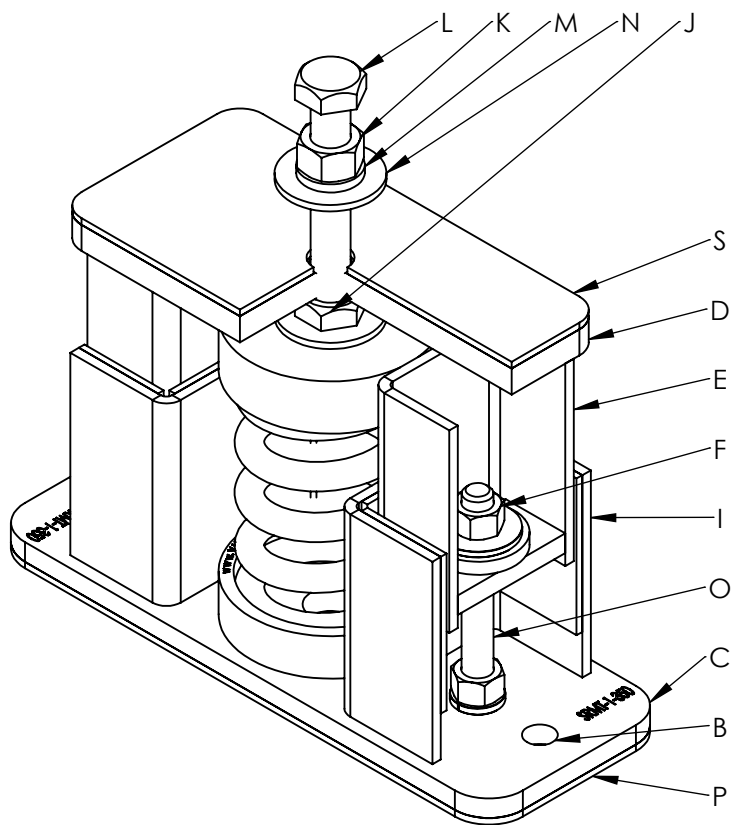

VibraSystems Inc
 www.vibrasystems.com
 email: info@vibrasystems.com

INSTALLATION INSTRUCTIONS

SCALE:	MODEL:	REV	
None	SRMT-1-350	A	
SHEET 2 OF 2			