

Model	Rated Load (lbs)	Deflec. @ Rated Load (in)	Spring Rate (lbs/in)	Max. Combined Vert. / Horiz. G Rating	Spring Color
SRMT-2-352	280	1.5	187	36.9	Yellow
SRMT-2-354	500	1.5	333	20.7	Purple
SRMT-2-354-142	770	1.5	513	13.4	Purple/Blue
SRMT-2-354-144	1,300	1.5	867	7.9	Purple/Brown
SRMT-2-354-146	2,000	1.5	1,333	5.2	Purple/Yellow
SRMT-2-354-148	2,600	1.25	2,080	4.0	Purple/Green

Model	Rated Load (lbs)	Deflec. @ Rated Load (in)	Spring Rate (lbs/in)	Max. Combined Vert. / Horiz. G Rating	Spring Color
SRMT-2-350	160	2	80	64.6	Red
SRMT-2-350-140	320	2	160	32.3	Red/Black
SRMT-2-403	696	2	348	14.8	Black
SRMT-2-404	906	2	453	11.4	Blue
SRMT-2-405	1,180	2	590	8.8	Red
SRMT-2-406	1,352	2	676	7.6	Orange
SRMT-2-407	1,574	2	787	6.6	Green
SRMT-2-408	1,836	2	918	5.6	White
SRMT-2-409	2,000	2	1,000	5.2	Brown
SRMT-2-410	2,500	2	1,250	4.1	White
SRMT-2-407-150	2,874	2	1,437	3.6	Green/Grey
SRMT-2-409-150	3,300	2	1,650	3.1	Brown/Grey
SRMT-2-410-150	3,800	2	1,900	2.7	White/Grey

Notes:

- Standard finish: Housing - Zinc Bright Plating; Spring - Zinc Bright Plating (Color: see table); Hardware - Zinc-electroplate.
- Safety factor - Springs will accommodate 50% extra load from rated load to solid load.
- Vibrasystems isolators are tested and certified to ASHRAE 171-2017 for wind and seismic load resistance. Wind and Seismic Certification Compliance Report 1701502-CR-001.

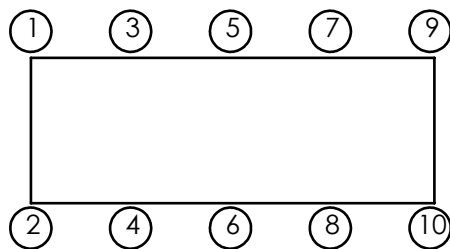

Isolator Selections			
Pos 1		Pos 2	
Pos 3		Pos 4	
Pos 5		Pos 6	
Pos 7		Pos 8	
Pos 9		Pos 10	

VibraSystems Inc
 www.vibrasystems.com
 email: info@vibrasystems.com

INSTALLATION INSTRUCTIONS

SCALE: None	MODEL: SRMT-2-350	SHEET 1 OF 2	REV A
-------------	-------------------	--------------	-------

1. Check each isolator's model number ("A") against the information on the packing slip, before beginning installation.
2. Secure the isolator to the equipment support structure - concrete foundation or metal frame, according to the equipment base's drawings for the locations of the mounting holes ("B").
 - 2.1. If the isolator is installed on a concrete foundation, use sets of seismically rated concrete anchors and follow the general anchor installation instructions with the required torque value on the anchor's nut.
 - 2.2. If the isolator is installed on a metal base, use grade 5 or better hardware to secure the isolator to the support base. Welding to steel base is permitted provided the weld achieves the required strength. Remove the rubber pad ("P") before welding.
 - 2.3. Vibrasystems Inc. recommends that all the isolators are installed on a level surface.

3. Use a forklift, crane or any other certified lifting machine to raise the equipment to be installed. Slowly lower the equipment on top of the isolators and make sure that equipment base's holes perfectly aligned with the threaded hole on the isolator's top plate ("D").
4. Make sure that the isolator's threaded rod ("L") properly fit through the holes in the base of the equipment and into the threaded hole on the isolator's top plates ("D"). Threaded rod ("L") must have a flat washer ("N"), a spring washer ("M"), and a hexagon nut ("K"). Welding to steel base is permitted provided the weld achieves the required strength. Remove the rubber pad ("S") before welding.
5. When the equipment, which must be at the full operating weight, is placed onto the isolators, the isolator's spring will be compressed under the load according to the Load VS. Deflection chart for this isolator model. The inside channels ("E") will slide down along the outside channels ("I") of the isolator's base ("C") under the weight of the equipment.
6. Turn the threaded rod ("L") clockwise until it touches the bottom of thrust bolt ("J").
7. Level each isolator in sequence by turning threaded rod ("L") a full clockwise turn at a time. Repeat this procedure on all isolators, one at a time. After the leveling is done, run down the lock nut ("K"), the spring washer ("M") and the flat washer ("N") to secure the equipment to the isolator's top plate ("D").
8. Adjust the lock nuts ("F") to allow a free movement of the installed equipment at all mounting points, with an allowed gap of 1/4".
9. Installation is complete.

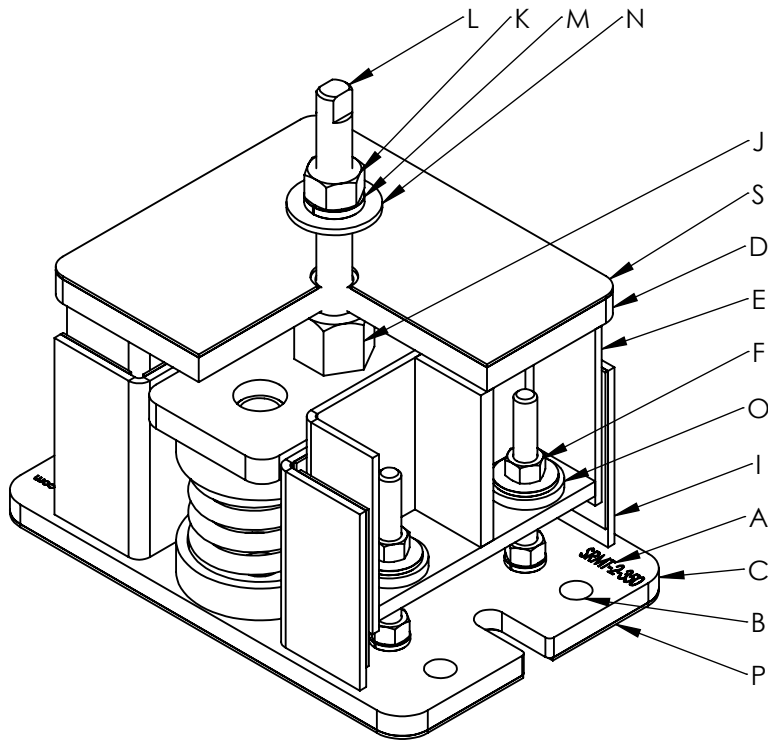

<u>VibraSystems Inc</u>			
www.vibrasystems.com email: info@vibrasystems.com			
INSTALLATION INSTRUCTIONS			
SCALE:	MODEL:	SHEET 2 OF 2	REV
None	SRMT-2-350		A