

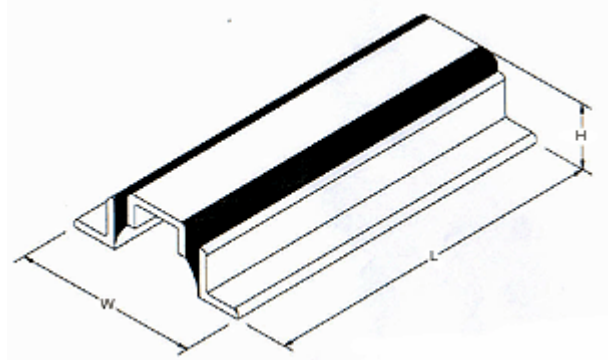

FSM / SM Series SANDWICH MOUNTS

VibraSystems channel mounts, type **FSM**, are versatile anti-vibration bars where both the top C channel and bottom angle flanges are accessible from both sides. This configuration allows the top and bottom plates to be drilled anywhere along their length for ease of installation. The plates are bonded together with neoprene elements, which allow up to 3/8" deflection at the maximum load of 50 psi.. Available in standard or custom-made lengths.



Product Code	Dimensions (ins)			Max Load (lbs)	Max Load (lbs / inch)
	L	W	H		
FSM-4	4	4-1/2	1-5/16	200	50
FSM-6	6	4-1/2	1-5/16	300	50
FSM-12	12	4-1/2	1-5/16	600	50
FSM-40	40	4-1/2	1-5/16	2000	50

VibraSystems type **SM** Sandwich Bars consist of two metal plates bonded with a neoprene insert. **SM** mounts effectively isolates against horizontal and vertical shock and vibration. **SM** mounts can be made in custom lengths up to 48" and also in custom widths and thickness. Threaded holes in the metal plates can be supplied on special orders.

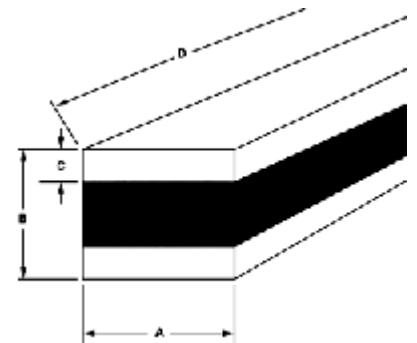

FEATURES:

- Low installation height provides good stability
- Effectively isolates against horizontal and vertical vibration and shock
- High deflection in the horizontal plane while vertical deflection is low
- Resistant to oil and grease
- Strong, reliable construction provides long life
- Increases machine accuracy and extends life of machinery and tools

Product Code	Dimensions (ins)				Max Load (lbs)
	A	B	C	D	
SM-1-(D)	2	1-3/4	3/8	2, 4, 6, 12, 40	800/1"
SM-2-(D)	3	2	3/8	3, 6, 12, 40	1100/1"
SM-3-(D)	4	2-3/8	5/8	4, 8, 12, 40	1400/1"